

The IDC logo consists of the lowercase letters 'idc' in a bold, sans-serif font, followed by a registered trademark symbol (®). The background of the entire page is a high-contrast, black and white photograph of a cylindrical roller thrust bearing, showing its rollers and raceways in detail.

IDC® - Bearings  
by INTERPRECISE Germany

圆柱滚子推力轴承

---

**Cylindrical Roller Thrust Bearings**

---

INTERPRECISE Donath GmbH  
Ostring 2  
90587 Obermichelbach  
Germany

Telefon +49-911-76630-0  
Telefax +49-911-76630-30

[info@interprecise.de](mailto:info@interprecise.de)  
[www.idc-bearings.com](http://www.idc-bearings.com)



## Cylindrical Roller Thrust Bearings

---

### 概述

推力圆柱滚子轴承适用于高轴向载荷，其特点是节省空间的轴向高度。此外，这些轴承具有很高的刚性和承载能力。推力圆柱滚子轴承是单向作用的标准轴承，有单列和双列两种设计。

推力圆柱滚子轴承有一个轴垫圈、一个轴承座垫圈和一个装有圆柱滚子的轴向滚子保持架。这些部件也可以单独提供。这在滚道集成在轴和/或轴承座中的情况下非常有用，因此可以省去轴垫圈和/或轴承座垫圈。

### 轴承通用技术信息

#### 尺寸

推力圆柱滚子轴承的主要尺寸符合 DIN 722 标准（单列设计--811 和 812 系列）和 DIN 616 及 ISO 104 标准（双列设计--893 和 894 系列）。

#### 工作温度

圆柱滚子推力轴承的工作温度范围为  $-30^{\circ}\text{C}$  to  $+150^{\circ}\text{C}$ 。  
受合成材料制成的保持架的限制，带有后缀TV的圆柱滚子推力轴承适用于 $-30^{\circ}\text{C}$ 至 $+120^{\circ}\text{C}$ 的工作温度。

#### 热处理工艺

套圈和滚子按标准完全硬化。

#### 极限转速

数据表中显示的极限转速值适用于油润滑。在脂润滑的情况下，极限转速等于该值的25%。



## Cylindrical Roller Thrust Bearings

### 不对中

圆柱滚子推力轴承不能容忍轴和轴承座之间的任何不对中或轴上和轴承座中的支撑面之间的任何角度偏差。

### 公差

根据 DIN 620-2 和 ISO 199 标准，推力圆柱滚子轴承的默认公差等级为 PN。根据要求，轴承零件也可以按照公差等级 P5 生产。

轴承零件的公差如下表所示：

		公差					
		孔		外径		高度	
轴向滚子保持架	K	d	E11 <sup>*1</sup>	D	a13 <sup>*1</sup>	D <sub>W</sub>	DIN 5402-1
轴圈	WS	d	DIN 620-3	d <sub>1</sub>	-	B	h11
座圈	GS	D <sub>1</sub>	-	D	DIN 620-3	B	h11

<sup>\*1</sup> 平均直径偏差

### 当量轴承载荷

动态:  $P = F_a$

静态:  $P_0 = F_a$





## Cylindrical Roller Thrust Bearings

### 最小轴向载荷

圆柱滚子推力轴承需要最小的轴向载荷，以确保无故障运行，特别是当轴承以高转速运行或承受高加速度时。

最小轴向载荷可以根据以下公式以足够的精度计算：

$$F_{a \min} = 0,0005 * C_{0a} + k_a * \left( \frac{C_{0a} * n}{10^3} \right)^2$$

Explanation:

$F_{a \min}$	最小轴向载荷 [N]
$C_{0a}$	额定轴向静载荷 [N]
$n$	运行转速 [r/min]
$k_a$	系数取决于轴承系列
	series 811      1,4
	series 812      0,9
	series 893      0,7
	series 894      0,5

在无法达到计算的最小轴向载荷的情况下，必须通过插入适当的弹簧或轴螺母对轴承进行预紧。

### 相邻部件的设计

轴承垫圈应尽可能完全支撑整个滚道。相邻的轴肩是刚性的，支撑面必须与轴轴线成直角。

圆柱滚子和保持架推力组件通常在轴上进行径向导向，尤其是在高速旋转时。导向区域必须具有精磨和耐磨的表面。

在使用推力圆柱滚子轴承时，如果不使用轴垫圈或/和轴承座垫圈，则接触区域必须具有适当的轴承部件表面和硬度质量。此外，还必须使用适当的滚子轴承钢。更多信息请联系我们。



## Cylindrical Roller Thrust Bearings

下表列出轴圈和座圈的公差。

		公差	
		轴	轴承座孔
轴向滚子保持架	K	h8	-
轴圈	WS	h8	-
座圈	GS	-	H9

### 后缀

此列表显示了交付品设计的后缀：

M 实体黄铜保持架，滚子引导\*1

P5 尺寸和运行公差精度高于 P6 \*2

TV 聚酰胺 6.6 保持架，滚子引导 \*1

\*1 保持架设计取决于轴承系列和尺寸

\*2 按需



**Baureihe / Series**  
**811**

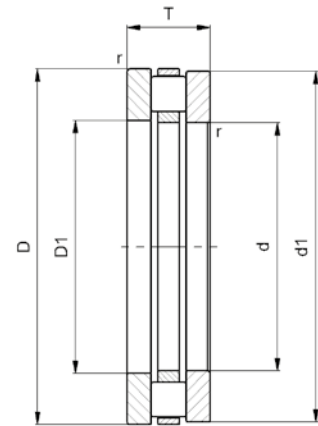
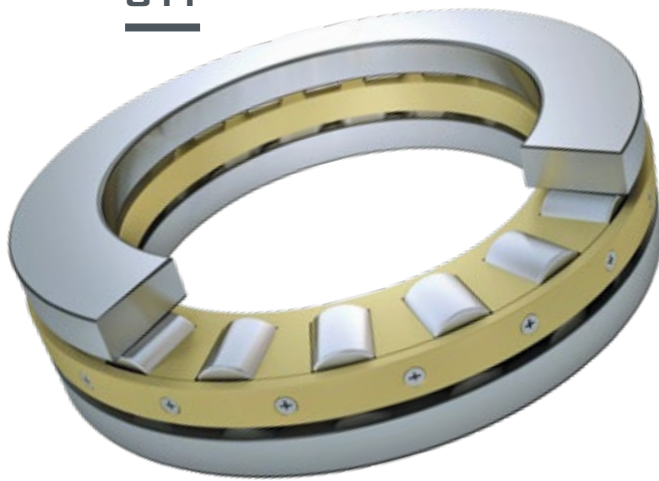

811

Bezeichnung description	Gewicht weight [kg]	Kurzzzeichen Lagerteile abbreviation bearing parts			Abmessungen measures [mm]				
		Axial-Rollenkranz axial roller and cage assembly	Gehäusescheibe housing washer	Wellenscheibe shaft washer	d	D	d <sub>1</sub>	D <sub>1</sub>	T
81120.TV	0,95	K 81120.TV	GS 81120	WS 81120	100	135	135	102	25
81122.TV	1,05	K 81122.TV	GS 81122	WS 81122	110	145	145	112	25
81124.TV	1,1	K 81124.TV	GS 81124	WS 81124	120	155	155	122	25
81126.TV	1,7	K 81126.TV	GS 81126	WS 81126	130	170	170	132	30
81128.TV	1,9	K 81128.TV	GS 81128	WS 81128	140	180	178	142	31
81130.TV	2	K 81130.TV	GS 81130	WS 81130	150	190	188	152	31
81132.TV	2,2	K 81132.TV	GS 81132	WS 81132	160	200	198	162	31
81134.M	2,7	K 81134.M	GS 81134	WS 81134	170	215	213	172	34
81136.M	3,2	K 81136.M	GS 81136	WS 81136	180	225	222	183	34
81138.M	4,3	K 81138.M	GS 81138	WS 81138	190	240	237	193	37
81140.M	4,5	K 81140.M	GS 81140	WS 81140	200	250	247	203	37
81144.M	4,9	K 81144.M	GS 81144	WS 81144	220	270	267	223	37
81148.M	7,9	K 81148.M	GS 81148	WS 81148	240	300	297	243	45
81152.M	8,5	K 81152.M	GS 81152	WS 81152	260	320	317	263	45
81156.M	11,6	K 81156.M	GS 81156	WS 81156	280	350	347	283	53
81160.M	18	K 81160.M	GS 81160	WS 81160	300	380	376	304	62
81164.M	19,7	K 81164.M	GS 81164	WS 81164	320	400	396	324	63
81168.M	20,4	K 81168.M	GS 81168	WS 81168	340	420	416	344	64
81172.M	21,5	K 81172.M	GS 81172	WS 81172	360	440	436	364	65
81176.M	22,5	K 81176.M	GS 81176	WS 81176	380	460	456	384	65
81180.M	24	K 81180.M	GS 81180	WS 81180	400	480	476	404	65
81184.M	25	K 81184.M	GS 81184	WS 81184	420	500	495	424	65
81188.M	40	K 81188.M	GS 81188	WS 81188	440	540	535	444	80
81192.M	43	K 81192.M	GS 81192	WS 81192	460	560	555	464	80
81196.M	44,5	K 81196.M	GS 81196	WS 81196	480	580	575	484	80



**Baureihe / Series**  
**811**

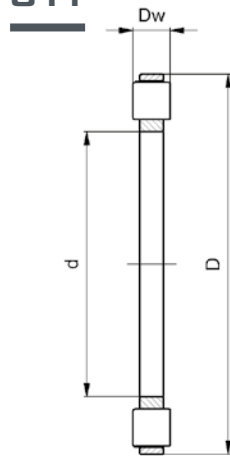

K 811

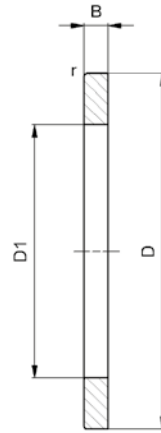

GS 811

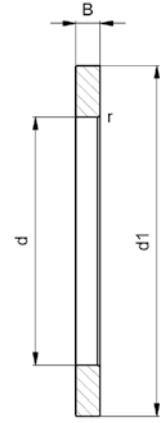

WS 811

Abmessungen measures [mm]			Tragzahlen load ratings		Ermüdungsgrenzbelastung fatigue limit load	Grenzdrehzahl limiting speed	Bezeichnung description
B	D <sub>w</sub>	r <sub>min</sub>	dyn. C <sub>a</sub> [kN]	stat. C <sub>0a</sub> [kN]	C <sub>ua</sub> [kN]	n <sub>G</sub> [min <sup>-1</sup> ]	
7	11	1	148	580	60	2400	81120.TV
7	11	1	154	630	63	2200	81122.TV
7	11	1	160	680	65	2200	81124.TV
9	12	1	190	815	78	1900	81126.TV
9,5	12	1	197	870	80	1800	81128.TV
9,5	12	1	204	930	83	1700	81130.TV
9,5	12	1	211	990	86	1700	81132.TV
10	14	1,1	265	1220	111	1600	81134.M
10	14	1,1	275	1300	112	1500	81136.M
11	15	1,1	315	1500	129	1400	81138.M
11	15	1,1	325	1590	133	1400	81140.M
11	15	1,1	340	1730	139	1300	81144.M
13,5	18	1,5	470	2370	191	1100	81148.M
13,5	18	1,5	490	2560	200	1100	81152.M
15,5	22	1,5	675	3460	275	950	81156.M
18,5	25	2	850	4380	340	850	81160.M
19	25	2	875	4630	350	800	81164.M
19,5	25	2	900	4890	360	800	81168.M
20	25	2	910	5020	365	750	81172.M
20	25	2	935	5280	375	750	81176.M
20	25	2	960	5530	385	700	81180.M
20	25	2	980	5790	395	700	81184.M
24	32	2,1	1420	8030	570	600	81188.M
24	32	2,1	1470	8450	585	600	81192.M
24	32	2,1	1480	8660	590	560	81196.M



**Baureihe / Series**  
**812**

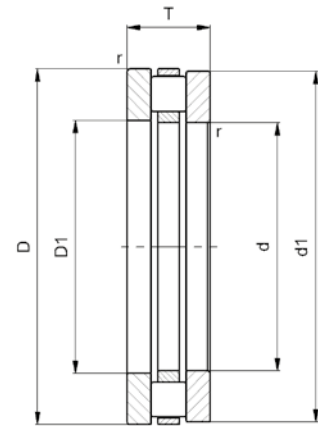

812

Bezeichnung description	Gewicht weight [kg]	Kurzeichen Lagerteile abbreviation bearing parts			Abmessungen measures [mm]				
		Axial-Rollenkranz axial roller and cage assembly	Gehäusescheibe housing washer	Wellenscheibe shaft washer	d	D	d <sub>1</sub>	D <sub>1</sub>	T
81218.M	1,8	K 81218.M	GS 81218	WS 81218	90	135	135	93	35
81220.M	2,3	K 81220.M	GS 81220	WS 81220	100	150	150	103	38
81222.M	2,4	K 81222.M	GS 81222	WS 81222	110	160	160	113	38
81224.M	2,7	K 81224.M	GS 81224	WS 81224	120	170	170	123	39
81226.M	4,3	K 81226.M	GS 81226	WS 81226	130	190	187	133	45
81228.M	4,8	K 81228.M	GS 81228	WS 81228	140	200	197	143	46
81230.M	6,6	K 81230.M	GS 81230	WS 81230	150	215	212	153	50
81232.M	7	K 81232.M	GS 81232	WS 81232	160	225	222	163	51
81234.M	8,5	K 81234.M	GS 81234	WS 81234	170	240	237	173	55
81236.M	9,1	K 81236.M	GS 81236	WS 81236	180	250	247	183	56
81238.M	11,7	K 81238.M	GS 81238	WS 81238	190	270	267	194	62
81240.M	13,1	K 81240.M	GS 81240	WS 81240	200	280	277	204	62
81244.M	14,2	K 81244.M	GS 81244	WS 81244	220	300	297	224	63
81248.M	24,5	K 81248.M	GS 81248	WS 81248	240	340	335	244	78
81252.M	26,5	K 81252.M	GS 81252	WS 81252	260	360	355	264	79
81256.M	29	K 81256.M	GS 81256	WS 81256	280	380	375	284	80
81260.M	43	K 81260.M	GS 81260	WS 81260	300	420	415	304	95
81264.M	45	K 81264.M	GS 81264	WS 81264	320	440	435	325	95
81268.M	48,5	K 81268.M	GS 81268	WS 81268	340	460	455	345	96
81272.M	68,5	K 81272.M	GS 81272	WS 81272	360	500	495	365	110
81276.M	74	K 81276.M	GS 81276	WS 81276	380	520	515	385	112
81280.M	77	K 81280.M	GS 81280	WS 81280	400	540	535	405	112
81284.M	104	K 81284.M	GS 81284	WS 81284	420	580	575	425	130
81288.M	114	K 81288.M	GS 81288	WS 81288	440	600	595	445	130
81292.M	119	K 81292.M	GS 81292	WS 81292	460	620	615	465	130
81296.M	134	K 81296.M	GS 81296	WS 81296	480	650	645	485	135





**Baureihe / Series**  
**812**

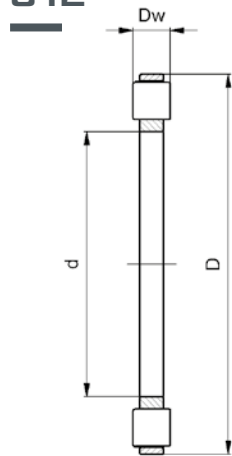

K 812

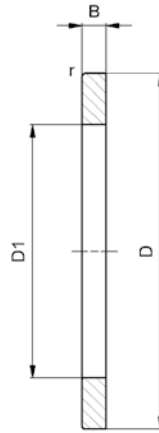

GS 812



WS 812

Abmessungen measures [mm]			Tragzahlen load ratings		Ermüdungsgrenzbelastung fatigue limit load	Grenzdrehzahl limiting speed	Bezeichnung description
B	D <sub>w</sub>	r <sub>min</sub>	dyn. C <sub>a</sub> [kN]	stat. C <sub>0a</sub> [kN]	C <sub>ua</sub> [kN]	n <sub>G</sub> [min <sup>-1</sup> ]	
10,5	14	1,1	220	790	83	2000	81218.M
11,5	15	1,1	255	960	98	1800	81220.M
11,5	15	1,1	250	960	96	1700	81222.M
12	15	1,1	255	1010	98	1600	81224.M
13	19	1,5	365	1400	136	1400	81226.M
13,5	19	1,5	375	1470	138	1400	81228.M
14,5	21	1,5	450	1800	167	1300	81230.M
15	21	1,5	465	1890	172	1200	81232.M
16,5	22	1,5	525	2180	194	1100	81234.M
17	22	1,5	535	2280	198	1100	81236.M
18	26	2	700	2930	260	1000	81238.M
18	26	2	720	3070	265	1000	81240.M
18,5	26	2	755	3350	280	950	81244.M
23	32	2,1	1060	4650	390	800	81248.M
23,5	32	2,1	1080	4860	400	750	81252.M
24	32	2,1	1140	5280	420	750	81256.M
28,5	38	3	1500	6850	530	630	81260.M
28,5	38	3	1560	7440	560	600	81264.M
29	38	3	1600	7740	570	600	81268.M
32,5	45	4	2090	9980	700	530	81272.M
33,5	45	4	2140	10400	735	530	81276.M
33,5	45	4	2200	11000	760	500	81280.M
39	52	5	2780	13600	925	430	81284.M
39	52	5	2810	14000	935	430	81288.M
39	52	5	2870	14600	955	430	81292.M
39,5	56	5	3230	16300	1080	400	81296.M



**Baureihe / Series**  
**893**

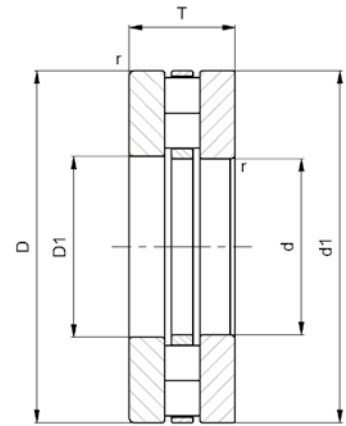
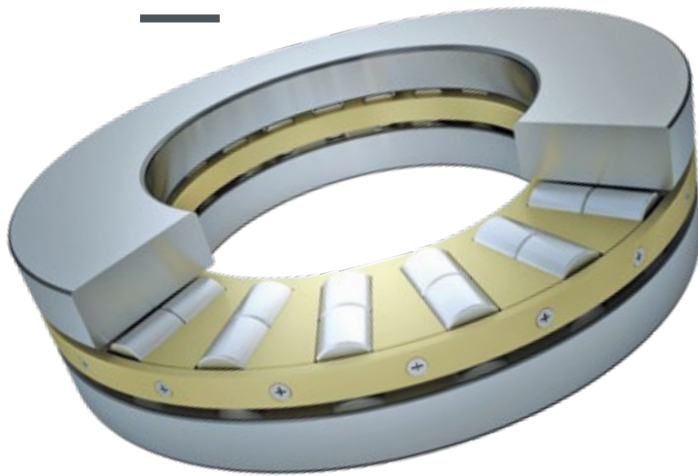

893

Bezeichnung description	Gewicht weight [kg]	Kurzzzeichen Lagerteile abbreviation bearing parts			Abmessungen measures [mm]				
		Axial-Rollenkranz axial roller and cage assembly	Gehäusescheibe housing washer	Wellenscheibe shaft washer	d	D	d <sub>1</sub>	D <sub>1</sub>	T
89317.M	3,2	K 89317.M	GS 89317	WS 89317	85	150	150	88	39
89318.M	3,5	K 89318.M	GS 89318	WS 89318	90	155	155	93	39
89320.M	4,5	K 89320.M	GS 89320	WS 89320	100	170	170	103	42
89322.M	6,6	K 89322.M	GS 89322	WS 89322	110	190	190	113	48
89324.M	9,2	K 89324.M	GS 89324	WS 89324	120	210	210	123	54
89326.M	10,8	K 89326.M	GS 89326	WS 89326	130	225	225	134	58
89328.M	12,6	K 89328.M	GS 89328	WS 89328	140	240	240	144	60
89330.M	13,2	K 89330.M	GS 89330	WS 89330	150	250	250	154	60
89332.M	17,5	K 89332.M	GS 89332	WS 89332	160	270	270	164	67
89334.M	18,6	K 89334.M	GS 89334	WS 89334	170	280	280	174	67
89336.M	23,2	K 89336.M	GS 89336	WS 89336	180	300	300	184	73



**Baureihe / Series**  
**893**

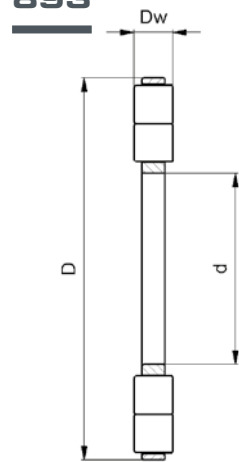

K 893

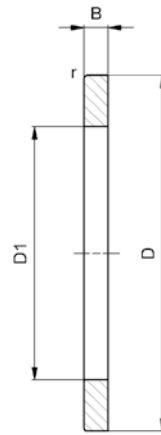

GS 893

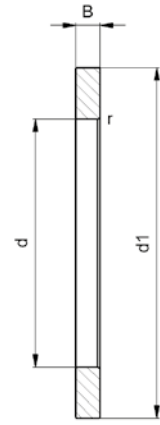

WS 893

Abmessungen measures [mm]			Tragzahlen load ratings		Ermüdungsgrenzbelastung fatigue limit load	Grenzdrehzahl limiting speed	Bezeichnung description
B	D <sub>w</sub>	r <sub>min</sub>	dyn. C <sub>a</sub> [kN]	stat. C <sub>0a</sub> [kN]	C <sub>ua</sub> [kN]	n <sub>G</sub> [min <sup>-1</sup> ]	
13,5	12	1,5	255	1100	107	2200	89317.M
13,5	12	1,5	265	1160	110	2000	89318.M
14,5	13	1,5	305	1350	126	1900	89320.M
16,5	15	2	400	1820	167	1700	89322.M
18,5	17	2,1	490	2220	204	1500	89324.M
20	18	2,1	565	2630	235	1400	89326.M
20,5	19	2,1	625	2950	260	1300	89328.M
20,5	19	2,1	640	3100	270	1300	89330.M
23	21	3	800	3940	335	1200	89332.M
23	21	3	820	4120	340	1100	89334.M
24,5	24	3	1010	4970	420	1100	89336.M



**Baureihe / Series**  
**894**

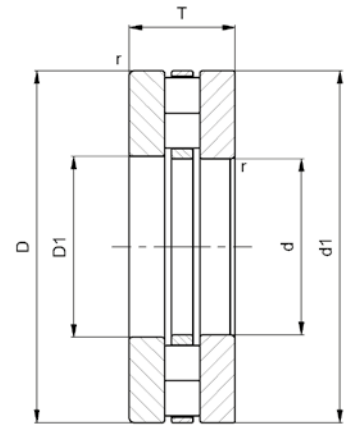
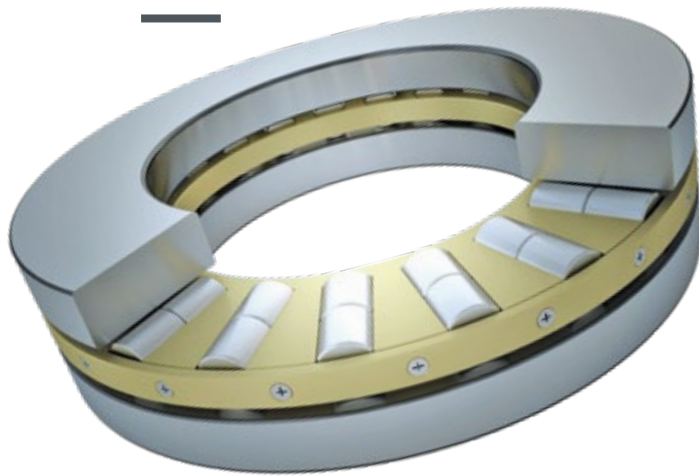

894

Bezeichnung description	Gewicht weight [kg]	Kurzzzeichen Lagerteile abbreviation bearing parts			Abmessungen measures [mm]				
		Axial-Rollenkranz axial roller and cage assembly	Gehäusescheibe housing washer	Wellenscheibe shaft washer	d	D	d <sub>1</sub>	D <sub>1</sub>	T
89416.M	7,7	K 89416.M	GS 89416	WS 89416	80	170	170	83	54
89417.M	8,2	K 89417.M	GS 89417	WS 89417	85	180	180	88	58
89418.M	9,5	K 89418.M	GS 89418	WS 89418	90	190	190	93	60
89420.M	12,7	K 89420.M	GS 89420	WS 89420	100	210	210	103	67
89422.M	16,5	K 89422.M	GS 89422	WS 89422	110	230	230	113	73
89424.M	20,7	K 89424.M	GS 89424	WS 89424	120	250	250	123	78
89426.M	25,5	K 89426.M	GS 89426	WS 89426	130	270	270	134	85
89428.M	28,5	K 89428.M	GS 89428	WS 89428	140	280	280	144	85
89430.M	34	K 89430.M	GS 89430	WS 89430	150	300	300	154	90
89432.M	40	K 89432.M	GS 89432	WS 89432	160	320	320	164	95
89434.M	49,5	K 89434.M	GS 89434	WS 89434	170	340	340	174	103
89436.M	57,5	K 89436.M	GS 89436	WS 89436	180	360	360	184	109
89438.M	69	K 89438.M	GS 89438	WS 89438	190	380	380	195	115
89440.M	79	K 89440.M	GS 89440	WS 89440	200	400	400	205	122
89444.M	86	K 89444.M	GS 89444	WS 89444	220	420	420	225	122
89448.M	92	K 89448.M	GS 89448	WS 89448	240	440	440	245	122
89452.M	120	K 89452.M	GS 89452	WS 89452	260	480	480	265	132
89456.M	151	K 89456.M	GS 89456	WS 89456	280	520	520	285	145
89460.M	162	K 89460.M	GS 89460	WS 89460	300	540	540	305	145
89464.M	200	K 89464.M	GS 89464	WS 89464	320	580	580	325	155





**Baureihe / Series**  
**894**

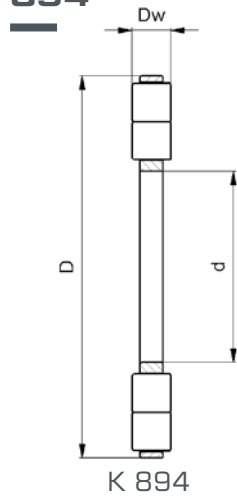

K 894

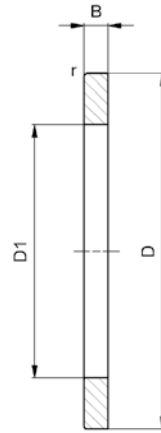

GS 894

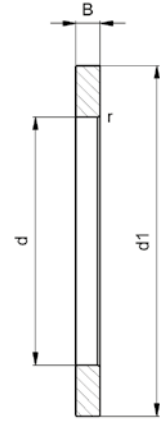

WS 894

Abmessungen measures [mm]			Tragzahlen load ratings		Ermüdungsgrenzbelastung fatigue limit load	Grenzdrehzahl limiting speed	Bezeichnung description
B	D <sub>w</sub>	r <sub>min</sub>	dyn. C <sub>a</sub> [kN]	stat. C <sub>0a</sub> [kN]	C <sub>ua</sub> [kN]	n <sub>G</sub> [min <sup>-1</sup> ]	
18	18	2,1	440	1710	170	1800	89416.M
19	20	2,1	515	1960	198	1700	89417.M
20	20	2,1	540	2130	208	1600	89418.M
22,5	22	3	640	2570	250	1400	89420.M
24,5	24	3	800	3300	305	1300	89422.M
26	26	4	930	3900	355	1200	89424.M
28,5	28	4	1060	4500	405	1100	89426.M
28,5	28	4	1100	4800	420	1100	89428.M
30	30	4	1260	5500	480	1000	89430.M
31,5	32	5	1420	6300	545	950	89432.M
34,5	34	5	1590	7200	610	850	89434.M
36,5	36	5	1760	8000	670	800	89436.M
38,5	38	5	1950	8900	750	750	89438.M
41	40	5	2150	9900	820	700	89440.M
41	40	6	2330	11200	890	700	89444.M
41	40	6	2400	11900	920	670	89448.M
44	44	6	2850	14300	1090	630	89452.M
48,5	48	6	3370	17100	1290	560	89456.M
48,5	48	6	3470	18000	1330	530	89460.M
51,5	52	6	3830	19800	1470	500	89464.M

The IDC logo consists of the lowercase letters 'idc' in a bold, sans-serif font, followed by a small square icon containing a stylized 'd'.

圆柱滚子推力轴承

Cylindrical Roller Thrust Bearings

INTERPRECISE Donath GmbH  
Ostring 2  
90587 Obermichelbach  
Germany

Telefon +49-911-76630-0  
Telefax +49-911-76630-30

info@interprecise.de  
www.idc-bearings.com